

### CONSTRUCTION NOTES

Core material:	Grenamat A
Density:	700 kg/m <sup>3</sup> ± 10%
Thickness of board:	16 mm
Surface finish:	HPL, Aluminum, paint
Thickness of surface:	0.8 mm
Junction:	Omega profile
Weight:	13.15 kg/m <sup>2</sup>
Sound reduction	29 dB

## CEILING

### B - 15

#### Omega profile joint

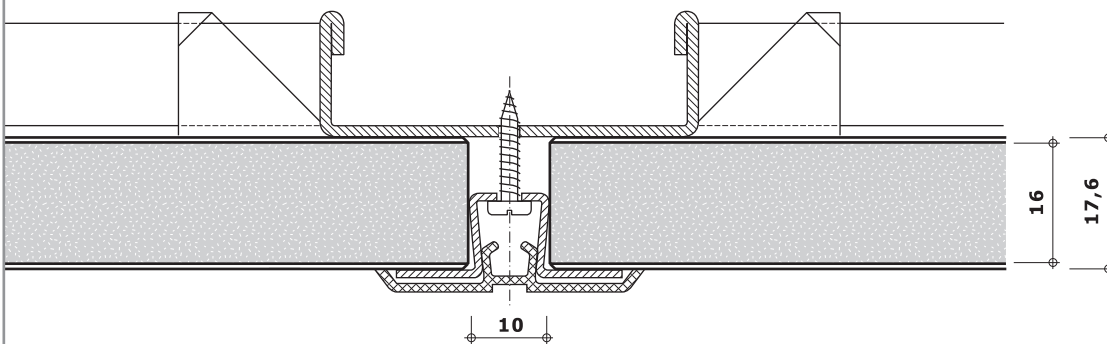

No.		Description	Weight length
RT 150/15		Ceiling support channel	0,95 kg/m 2440 mm
RT 310/10		Omega profile for panel joint	0,30 kg/m 2440 mm
RT 1483		PVC - cover white, cream, beige	0,07 kg/m 2440 mm
RT 1495		PVC - cover white, cream, beige	0,07 kg/m 2440 mm

