

CEILING

B - 0

Omega profile joint

CONSTRUCTION NOTES

Core material:	Grenamat A
Density:	800 kg/m ³ ± 10%
Thickness of board:	10 mm
Surface finish:	HPL, Aluminum, paint
Thickness of surface:	0.8 mm
Junction:	Omega profile
Weight:	11.71 kg/m ²
Sound reduction	28 dB

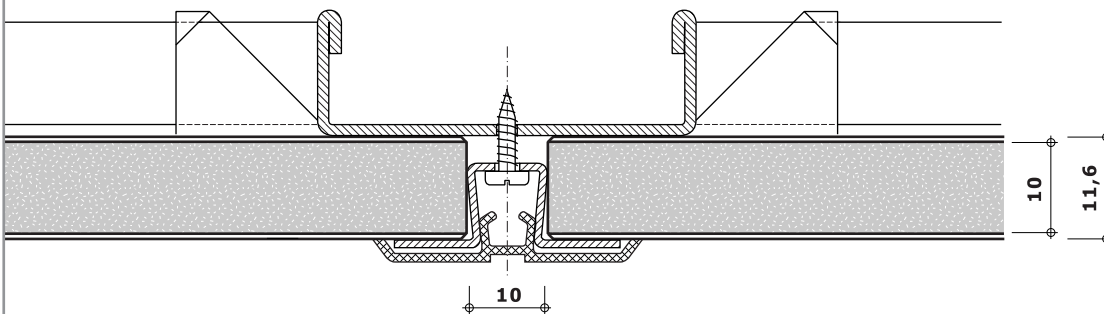

No.	Description	Weight length
RT 150/15		0,95 kg/m 2440 mm
RT 310/10		0,30 kg/m 2440 mm
RT 1483		0,07 kg/m 2440 mm
RT 1495		0,07 kg/m 2440 mm

